

Ecomatic
Autwomatic
Autwomatic Plus
Autwomatic Plus 1+2
Ultramatic GR
Ultramatic Plus



The alternative in Water Purification Systems”

Wasserlab, a firm with over 15 years of experience, designs and manufactures water purification systems to satisfy the daily Pure and Ultrapure Water requirements of laboratories and companies.

We are manufacturers, and therefore we are in a position to offer both, standard equipment and user bespoke equipment.

Wasserlab offers the market's best quality/price ratio for its water purification systems, together with its Maintenance and Technical Assistance Service.

Our company's philosophy focuses on providing our clients with the fastest and most efficient after sales service.

We offer different solutions to your different laboratory or company needs:

- Type I Ultrapure Water (Reagent Grade)
- Type II Purified Water (Analytical Grade)
- Type III Water (Osmotized)



The products are designed for use in:

LABORATORIES
Desktop equipment

HOSPITALS
High production
equipment

INDUSTRY
Bespoke facilities

Type I and II Water specifications according to ASTM (American Society for Testing and Materials)

Characteristic	Type I (Reagent Grade) Water	Type II (Analytical Grade) Water	Type III (Osmotized) Water	Type IV
Conductivity ($\mu\text{S/cm}$)	0,056	1,0	4	5
Resistivity ($\text{M}\Omega\cdot\text{cm}$)	18,2	1,0	0,25	0,2
Total Organic Carbon (ppb)	10	50	200	
Sodium (ppb)	1	5	10	50
Chloride (ppb)	1	5	10	50
Total Silica (ppb)	3	3		
Endotoxins (IU/ml.)	< 0,03	< 0,25	-	-

Bacterial content ufc/ml <1. It requires use of 0,22 μm final filter.

Clinical and Laboratory Standards Institute (CLSI)

Parameter	Type I (Reagent Grade) Water	Type II (Analytical Grade) Water	Type III (Osmotized) Water
Bacteria (cfu/ml)	< 1	< 100	< 1000
Resistivity ($\text{M}\Omega\cdot\text{cm}$ @ 25°C)	> 18	> 1	> 0,05
Silica (ppb)	< 10	< 100	< 1000
TOC (ppb)	< 10	< 50	< 200
Pyrogens (EU/ml)	< 0,03	-	-

ECOMATIC

PURIFIED WATER (TYPE II)

OSMOTIZED WATER (TYPE III)

Water that is always freshly produced, with stable quality and the best performance at the lowest cost.

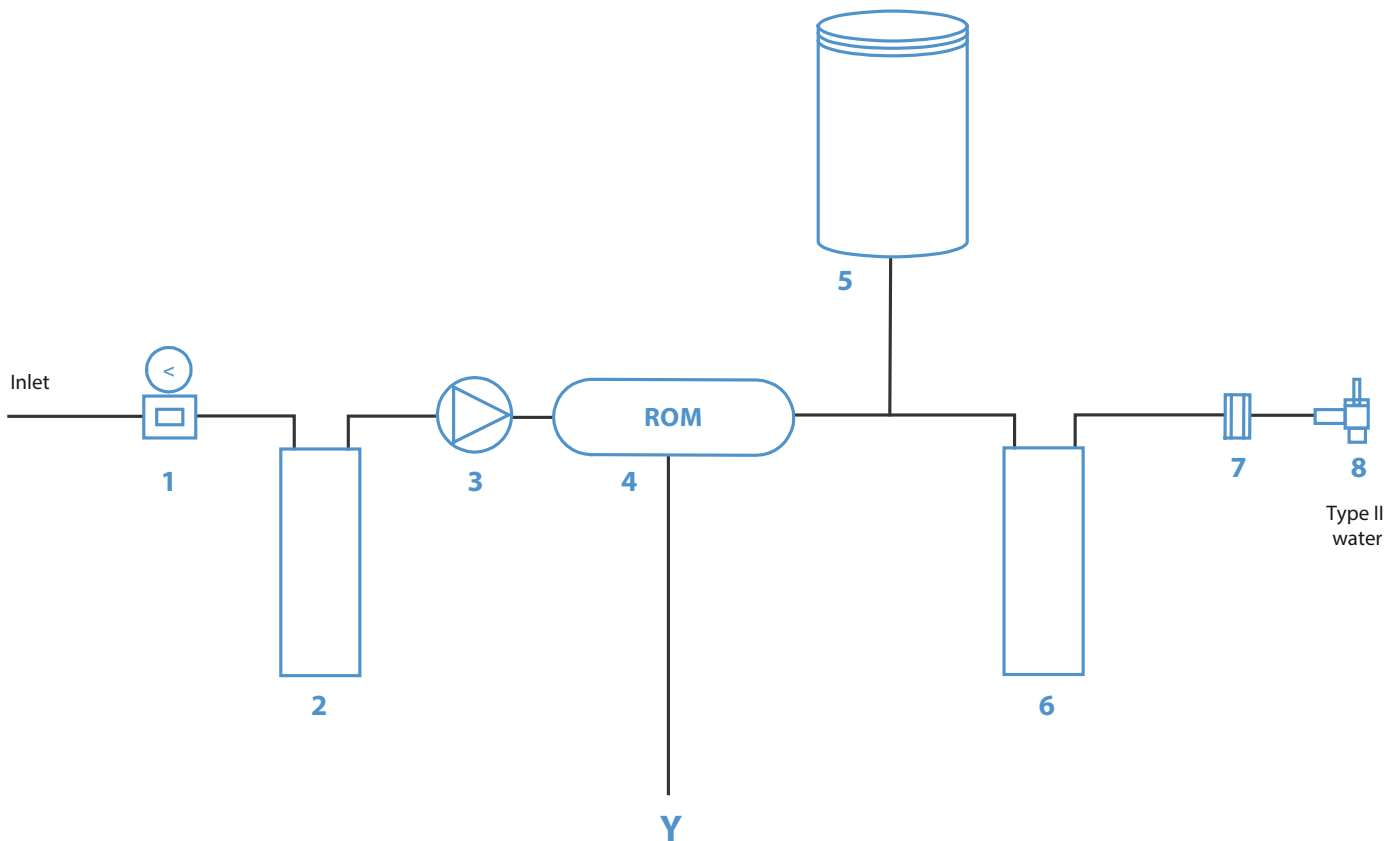

The Ecomatic Equipment
always dispenses freshly
purified Type II Water

1 Pressure Regulator. 2 Pretreatment module. 3 Pump. 4 Reverse Osmosis membrane. 5 Pressure Tank. 6 DI module.
7 Type II water conductivity sensor. 8 Dispensation tap.

Ecomatic: Compact water purification equipment that produces Type II (ASTM*, Analytical Grade) Water, using water directly from the mains

*American Society for Testing and Materials



Ecomatic provides Type II (Analytical Grade) Water, with productions of 3, 5 and 10 l/h, according to model

The combination of water purification systems using inverse osmosis and deionization, provides purified water with a stable quality, at a very competitive price.

The equipment **always dispenses freshly produced Type II Water**, avoiding its deterioration caused by storage.

Accumulation of Osmotized water

The permeate water from the reverse osmosis module accumulates in a pressurized tank (30 or 50 liters), which is opaque and airtight and protects the water from any contact with light and air, thereby preserving it from any possible contamination.



Easy to handle

Easy to install.
Easy, quick maintenance, thanks to its system of exchangeable cartridges, using fast connections.



Type II Water Monitoring

Continuous control of the purification process using a microprocessor

An easy-to-read digital screen informs users, at all times, of the following conditions:

- | The quality of the water produced measured in $\mu\text{S}/\text{cm}$, with a resolution of $\pm 0,1 \mu\text{S}/\text{cm}$.
- | The status of the purification process (in production, full tank, equipment dispensing) and warnings, using easy-to-interpret symbols.

Fully automatic operation for maximum tranquility for users.

Warning set point parameters can be programmed as desired.

Applications

More than 90% of general laboratory assays require Type II Water:

- | Preparation of culture media
- | Preparation of reagents and buffer solutions
- | Cleaning the material
- | Clinical Analyses
- | Salt spray Chambers and Climatic Test Chambers
- | Supplying equipment to produce Type I (Ultrapure) Water
- | Ecomatic can also provide Type III (Osmotized) Water for thermal disinfection devices and Autoclaves.

AUTWOMATIC

PURIFIED WATER (TYPE II)
OSMOTIZED WATER (TYPE III)



“Always freshly produced water, with controlled, monitored quality”

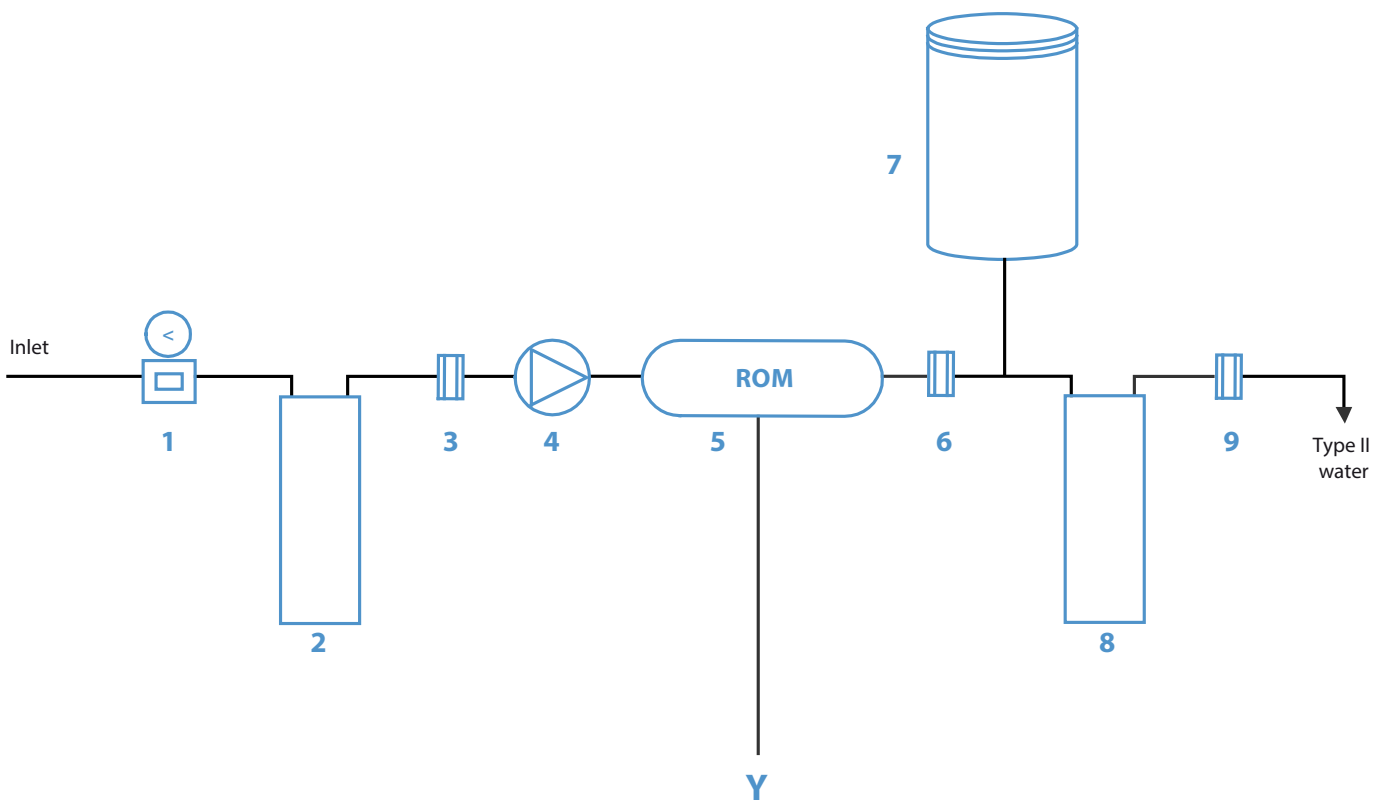

Autwomatic equipment:
Maximum tranquility for users

- 1 Pressure regulator. 2 Pretreatment module. 3 Inlet water conductivity sensor. 4 Pump. 5 Reverse osmosis membrane.
6 Osmotized water conductivity sensor. 7 Pressure tank . 8 DI module. 9 Type II water conductivity/temp sensor.

Pretreatment

The pretreatment module protects the reverse osmosis membrane by removing:

- ▮ Particles (≥ 5 micron)
- ▮ Chloride and colloids
- ▮ Organic material

Reverse osmosis

The high efficiency and performance reverse osmosis module provides with a flow rate of 3, 5 and 10 liters per hour of Osmotized water, removing:

- ▮ 95-98% of dissolved inorganic salts.
- ▮ >99% of dissolved organic matter (PM > 100 dalton).
- ▮ >99,95% of microorganisms and particles.

Deionization

A highly effective mixed bed of anion/cation ionic exchange resins removes any ions from the permeate water from the inverse osmosis module. The resulting water has a conductivity value $\leq 1 \mu\text{S/cm}$.

Monitoring

The Automatic microprocessor constantly monitors all the purification process parameters:

- ▮ Real number of equipment operating hours.
- ▮ Measurement in $\mu\text{S/cm}$ ($\pm 1 \mu\text{S/cm}$) of the conductivity of the equipment supply water and the permeate water from the reverse osmosis module.
- ▮ % performance of the reverse osmosis module ($\pm 0.1\%$).

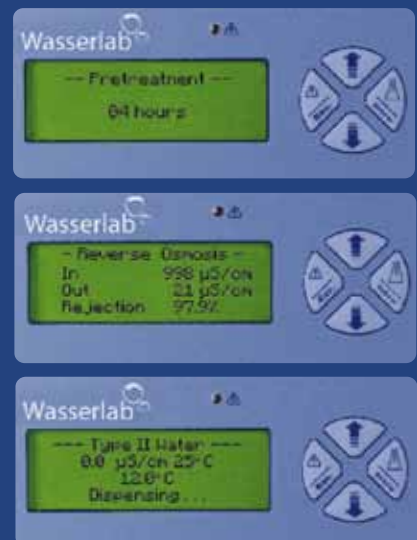

- ▮ Measurement in $\mu\text{S/cm}$ of the conductivity of the Type II Water produced ($\pm 0,1 \mu\text{S/cm}$).
- ▮ Water temperature. All the conductivity measurements are compensated at 25°C.
- ▮ Equipment operating status (Producing/Full Tank/Dispensing).



Accumulation of Osmotized water

The permeate water from the reverse osmosis module accumulates in a pressurized tank (30 or 50 liters), which is opaque and airtight and protects the water from any contact with light and air, thereby preserving it from any possible contamination.

Automatic equipment with multi-parameter monitoring

Type II (Analytical Grade) Water

The Autwomatic equipment stores the Osmotized water, unlike other purification systems which store the Type II Water end product, with the subsequent loss of quality.

Upon user's request, the Autwomatic always dispenses maximum quality, freshly purified Type II water.

Self-checking and preventive maintenance

The Autwomatic software is configured to conduct a programmed self-check on system operation, constantly and effectively controlling the equipment components and the monitoring values of the quality of the water produced.

Users can program the following as desired:

- Minimum performance of the reverse osmosis module.
- Maximum conductivity of the Type II Water produced.

to anticipate any possible problems caused by using water of a non-desired quality.



The microprocessor will provide with a preventive notification, in the form of an audible warning and a written message on the screen, indicating the maintenance tasks required to guarantee the desired water quality.

- Low performance of the reverse osmosis module.
- Pretreatment and deionization Module Wear and Tear.
- Temperature sensor or conductivity sensors not working properly.

Conductivity meter calibration and system check

The Autwomatic software allows adjusting and calibrating the conductivity meter using a certified standard based on the International standards.

The Wasserlab Technical Assistance Service offers, at user's request:

- Regular equipment calibration service.
- Full system check over and corresponding certificate.

Purified Type II water Applications

- Preparing microbiological culture media
- Spectrophotometry
- RIA/ELISA
- AA-Flame
- Preparing buffer solutions
- Salt spray chambers
- Climatic Test Chambers

Osmotized Water (Type III) Applications

- Feeding Autoclaves and washing machines
- Glassware cleaning

Ecomatic – Autwomatic Technical Specifications

Equipment	ECOMATIC	AUTWOMATIC
Final Water Quality	Type II	Type II
Conductivity (µS/cm)	<1	<1
Rate and Storage		
Flow Rate LPH	3/5/10 l/h	3/5/10 l/h
Max. Flow rate Recommended LPD	30 - 50 - 100	30 - 50 - 100
RO Pressurized Tank (L)	30/50	30/50
Dispensation		
Manual Dispensing	✓	✓
Continuous Monitorization		
Touch Screen / Keyboard	Keyboard	Keyboard
Visual and audible warning messages	✓	✓
Feed Water Conductivity (µS/cm)		✓
Osmotized water Conductivity (µS/cm)		✓
Ionic Rejection %		✓
Final Water Conductivity (µS/cm)	✓	✓
Work Time counter	✓	✓
Water Temperature (°C)		✓
Temperature compensation	✓	✓
Warning to user messages		
Out of range parameters	✓	✓
Pretreatment cartridge exchange	✓	✓
RO exchange		✓
DI cartridge exchange	✓	✓
Feed water supply failure	✓	
Automatism		
Automatic Start/Stop	✓	✓
Automatic Stop/water supply failure	✓	✓
Other elements		
DI increasable	✓	✓
Dimensions (Height/Widht/Depth) [cm]	45x25x48	52x25x48
Weight [kg]	12	15
Power supply	110-220 VAC / 50-60 Hz	110-220 VAC / 50-60 Hz
Feed Water Requirements		
Min. Inlet Pressure	2 bar	2 bar
Max. Inlet Pressure	6 bar	6 bar
Max. Water Temperature	30 °C	30 °C
Max. Hardness	300 ppm (CaCO ₃)	300 ppm (CaCO ₃)
SDI (Silt Density Index)	< 5	< 5
Max. Feed Water conductivity	1000 µS/cm	1500 µS/cm
Free Chlorine	< 1 ppm	< 1 ppm
Turbidity	< 1NTU	< 1NTU

AUTWOMATIC PLUS

PURIFIED WATER (TYPE II)

OSMOTIZED WATER (TYPE III)

“Maximum performance and optimal control of the purification process on touch screen”:

- | Purified Water (Type II)
- | Osmotized Water (Type III)



The **Autwomatic Plus** range of equipment produce **Type II purified water** (according to ASTM standards) of maximum quality and **RO water (Type III)**, incorporating the latest technology in production and quality control of Purified Water.

Autwomatic Plus Model Configurations

Versions	Code	Purified Water Type II					
		Production rate	Double Osmosis System	Purification Module Water Type II	Storage Tank	UV lamp	Final filter 0,22 µm
Autw. Plus 3 L	QA03DP	3 l/h	-	X	30/50 Liters	-	-
Autw. Plus UV 3 L	QA03DPUV	3 l/h	-	X	30/50 Liters	X	X
Autw. Plus 5 L	QA05DP	5 l/h	-	X	30/50 Liters	-	-
Autw. Plus UV 5 L	QA05DPUV	5 l/h	-	X	30/50 Liters	X	X
Autw. Plus HC 5 L	QAHC05DP	5 l/h	X	X	30/50 Liters	-	-
Autw. Plus HC UV 5 L	QAHC05DPUV	5 l/h	X	X	30/50 Liters	X	X
Autw. Plus 10 L	QA10DP	10 l/h	-	X	50 Liters	-	-
Autw. Plus UV 10 L	QA10DPUV	10 l/h	-	X	50 Liters	X	X

Type II Water

Water quality at 25°C

- Conductivity < 1 $\mu\text{S}/\text{cm}$.
- $\text{TOC}^1 < 50$ ppb.
- Bacteria¹ < 1 cfu/ml.
- Particles¹ < 0,22 μm .

Volume production of Reverse Osmosis

- 3 l/h
- 5 l/h
- 10 l/h

Storage Tank

- 30 Liters
- 50 Liters

¹ Autwomatic Plus UV version

Applications:

- Preparing microbiological culture media.
- Preparing buffer solutions.
- RIA/ELISA.
- AA-Flame.
- Spectrophotometry.

Osmotized Water

RO water quality.

Removal of:

- 95-98% dissolved inorganic salts.
- > 99% dissolved organic material (PM > 100 dalton).
- >99,95% of microorganisms and particles.

Applications:

- Feeding Autoclaves and washing machines.
- Glassware cleaning.

Stages of water purification

RO Water

Pretreatment: System particle filters and activated carbon to remove particles ($\geq 5 \mu\text{m}$), chlorine, organic material and colloids.

Reverse Osmosis: Reverse Osmosis Module High efficiency and performance, provides with a production rate of 3, 5 and 10 l/h (depending on model), eliminating 95-98% of dissolved inorganic salts, > 99% of dissolved organic material (MW > 100 dalton) and 99.95% of microorganisms and particles.

HC version (high Conductivity) for high inlet water conductivity.

The **Autwomatic Plus HC**, incorporates a system of double Osmosis, suitable to work with inlet water having high conductivity, improving performance and reducing the consumption of ion exchange resin.

Available in version 5 l / h.

Accumulation of Osmotized water: The permeate water from the reverse osmosis module accumulates in a pressurized tank (30 or 50 liters), which is opaque and airtight and protects the water from any contact with light and air, thereby preserving it from any possible contamination. Available pressurized tanks 30 and 50 liters.



Type II Water

Deionization: A highly effective mixed bed of anion/cation ionic exchange resins, removes any ions from the permeate water from the inverse osmosis module. The resulting water has a conductivity value $\leq 1 \mu\text{S}/\text{cm}$.

Ultraviolet Lamp and 0,22 μm Final Filter (Autwomatic Plus UV and Autwomatic Plus HC UV versions).

For a reduction of microorganisms present in the water, the equipment incorporates a UV lamp reducing this contamination.

In order to achieve even stricter microbiological requirements (<1 cfu/ml) a final filter of 0,22 μm is placed in the dispensing point, thus retaining any microorganisms in the final water.



Dispensation

The Autwomatic Plus dispenses two water qualities independently.

In order to obtain water Type II, the system allows three types of dispensing:

- | Continuous
- | Volume wise
- | Time control

The RO water is obtained directly from the pressurized tank.



Monitoring

Through a touch screen of 4.3", the Autwomatic Plus monitors all the parameters of the water purification process of the equipment.

Water Quality

- | Measurement of the feeding water conductivity ($\mu\text{S}/\text{cm}$)
- | Measurement of the water permeate reverse osmosis module conductivity ($\mu\text{S}/\text{cm}$)
- | % performance of the reverse osmosis module
- | Measurement of the Type II Water conductivity ($\mu\text{S}/\text{cm}$)
- | Temperature of the water ($^{\circ}\text{C}$)

Parameter Control

- | Hours of installation and working for each item.
- | Total liters produced.
- | Hours of operation of the equipment

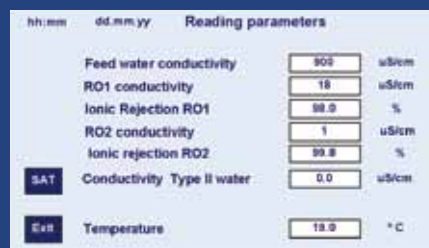
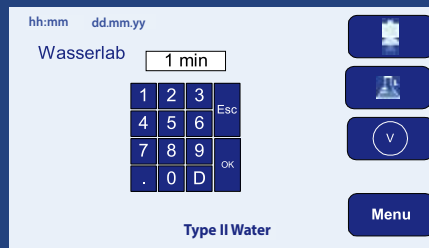
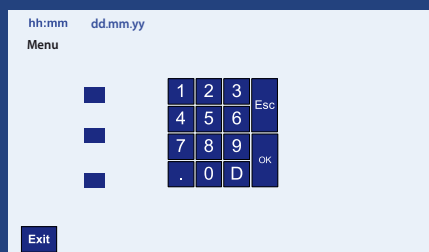

Security

The system has a user password to allow access to different parts of the menu, as well as for parameterization of the conductivity warning.

Automatism

Automatic operation depending on the volume of stored water.

System features:

- | Stop due to water cut.
- | Cleaning of the osmosis membrane.

The system warns about the change of consumables as well as abnormalities such as inlet water cut, or malfunction of the measuring sensors.

Maintenance, sanitization and calibration

Easy to use and maintain system.

Very quick Fungible change, with cartridges with fast connection and anti-drip system.

Possibility of sanitizing the hydraulic circuit.

Equipment calibrated by certified standard traceable to national standards of the German DKD.

CE Marking.

Autwomatic Plus

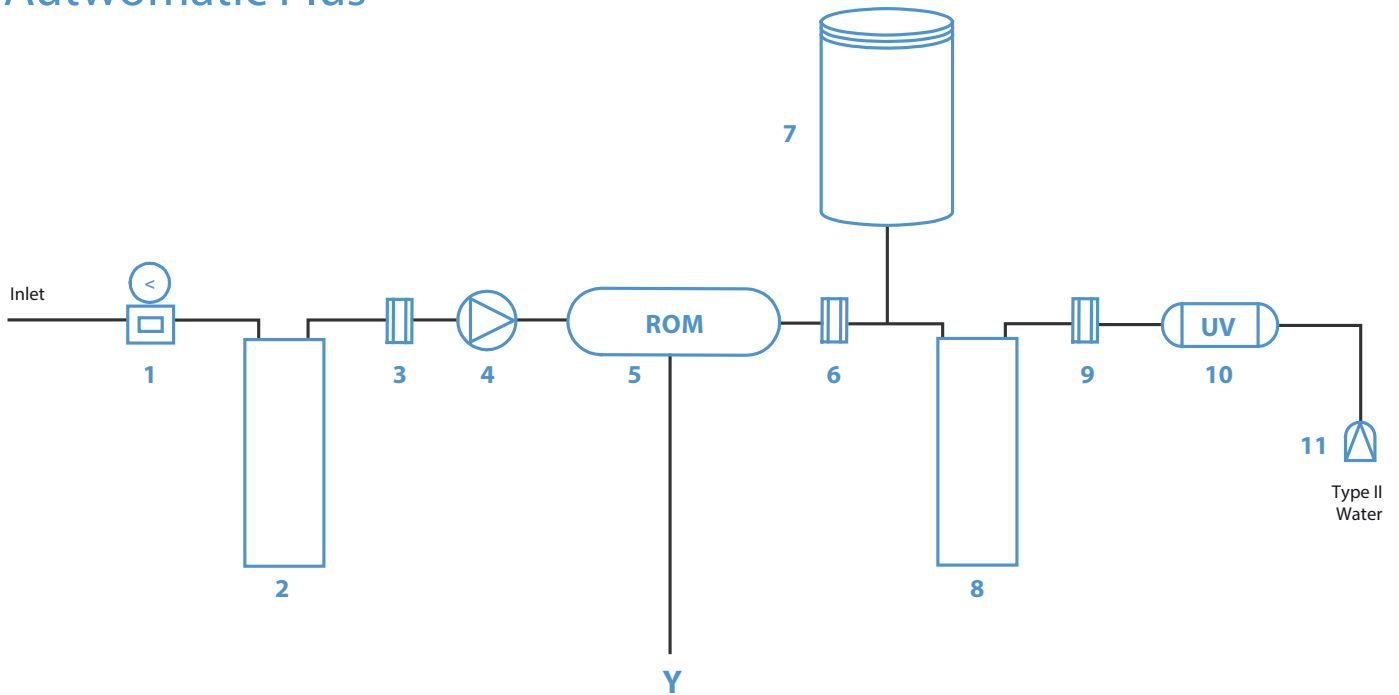

- 1 Pressure regulator. 2 Pretreatment module. 3 Inlet water conductivity/temp sensor. 4 Pump. 5 Reverse osmosis membrane.
 6 RO water conductivity sensor. 7 Pressure tank. 8 DI module. 9 Type II water Conductivity / Temp sensor. 10 UV lamp (optional).
 11 Final Filter 0,22 µm (optional).

Autwomatic Plus HC

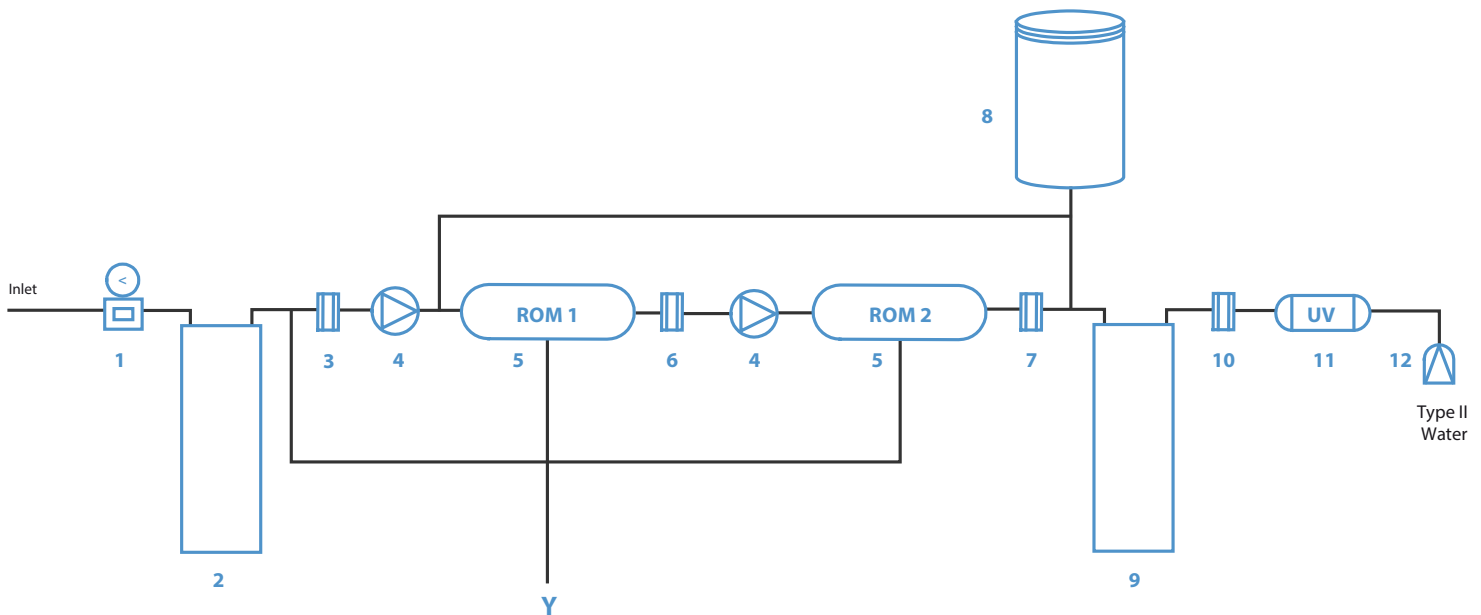

- 1 Pressure regulator. 2 Pretreatment module. 3 Inlet water conductivity/temp sensor. 4 Pump. 5 Reverse osmosis membrane.
 6 RO water conductivity sensor. 7 RO water conductivity sensor. 8 Pressure tank. 9 DI module. 10 Type II water Conductivity / Temp sensor.
 11 UV lamp (optional). 12 Final Filter 0,22 µm (optional).

Autwomatic Plus - Autwomatic HC Technical specifications

Equipment	AUTWOMATIC PLUS		AUTWOMATIC PLUS HC	
	AUTWOMATIC PLUS	AUTWOMATIC PLUS UV	AUTWOMATIC PLUS HC	AUTWOMATIC PLUS HC UV
Model	Type II	Type II	Type II	Type II
Final Water Quality				
Water Conductivity (µS/cm)	<1	<1	<1	<1
TOC (ppb)		<50		<50
Bacteria (cfu/ml)		<1		<1
Rate and Storage				
Flow Rate LPH	3/5/10 l/h	3/5/10 l/h	5 l/h	5 l/h
Double Osmosis Stage			√	√
Max. Flow rate Recommended LPD	30 - 50 - 100	30 - 50 - 100	50	50
RO Pressurized Tank (L)	30/50	30/50	30/50	30/50
Dispensation				
Manual Dispensing	√	√	√	√
Volume controlled Dispensing	√	√	√	√
Time Controlled dispensing	√	√	√	√
Continuous Monitoring				
Touch Screen/ keyboard	Touch Screen	Touch Screen	Touch Screen	Touch Screen
Visual and audible warning messages	√	√	√	√
Feed Water Conductivity (µS/cm)	√	√	√	√
Osmotized water Conductivity (µS/cm)	√	√	√	√
Ionic Rejection %	√	√	√	√
Final Water Conductivity (µS/cm)	√	√	√	√
Work Time counter	√	√	√	√
Multiparameter Time counter	√	√	√	√
Water Temperature (°C)	√	√	√	√
Temperature compensation	√	√	√	√
Warning to user messages				
Out of range parameters	√	√	√	√
Pretreatment cartridge exchange	√	√	√	√
RO exchange	√	√	√	√
DI cartridge exchange	√	√	√	√
UV lamp exchange		√		√
Final Filter exchange		√		√
Feed water supply failure	√	√	√	√
Automatismos				
Automatic Start/Stop	√	√	√	√
Automatic/Programmable recirculation	Programmable	Programmable	Programmable	Programmable
Automatic Stop/water supply failure	√	√	√	√
Automatic RO cleanning	√	√	√	√
Other components				
UV Lamp		√		√
Final Filter 0,22 µm		√		√
Dimensions (Height/Widht/Depth) [cm]				
	60x36x49	60x36x49	60x36x49	60x36x49
Weight [kg]				
	35	35	35	35
Power supply				
	110-220 VAC / 50-60 Hz	110-220 VAC / 50-60 Hz	110-220 VAC / 50-60 Hz	110-220 VAC / 50-60 Hz
Feed Water Requirements				
Min. Inlet Pressure	2 bar	2 bar	2 bar	2 bar
Max. Inlet Pressure	6 bar	6 bar	6 bar	6 bar
Max. Water Temperature	30 °C	30 °C	30 °C	30 °C
Max. Hardness	300 ppm (CaCO ₃)	300 ppm (CaCO ₃)	300 ppm (CaCO ₃)	300 ppm (CaCO ₃)
SDI (Silt Density Index)	< 5	< 5	< 5	< 5
Max. Feed Water conductivity	1500 µS/cm	1500 µS/cm	2000 µS/cm	2000 µS/cm
Free Chlorine	< 1 ppm	< 1 ppm	< 1 ppm	< 1 ppm
Turbidity	< 1NTU	< 1NTU	< 1NTU	< 1NTU

AUTWOMATIC PLUS 1+2

PURIFIED (TYPE II) AND ULTRAPURE (TYPE I) WATER

“Three qualities of water on a single Equipment, from tap water”:

- I Ultrapure Water (Type I)
- I Purified water (Type II)
- I Osmotized Water (Type III)



The range of equipment **Autwomatic Plus 1+2**, supplies RO water Type III, Purified water Type II and Ultrapure Water Type I (according to ASTM standards), of the highest quality, from three independent dispensers, including the highest technologies for production and quality control of Purified Water.

Configurations Autwomatic Plus 1+2 Model

Versions	Code	Purified Type II Water				Ultrapure Type I water				
		Production Rate	Purification Module Type II Water	Storage Tank	Final Filter 0,22 µm	Production Rate	Ultrapurification Module Type I	Foto-oxidation Lamp	Ultrafiltration Cartridge	Final Filter 0,22 µm
Autw. Plus 1+2 GR 3 L	QA03DPGR	3 l/h	X	10/30/50 Liters	X	1,1 l/min	X	X	-	X
Autw. Plus 1+2 GR 5 L	QA05DPGR	5 l/h	X	30/50 Liters	X	1,1 l/min	X	X	-	X
Autw. Plus 1+2 GR 10 L	QA10DPGR	10 l/h	X	30/50 Liters	X	1,1 l/min	X	X	-	X
Autw. Plus 1+2 GRUF 3 L	QA03DPGF	3 l/h	X	10/30/50 Liters	X	1,1 l/min	X	X	X	X
Autw. Plus 1+2 GRUF 5 L	QA05DPGF	5 l/h	X	30/50 Liters	X	1,1 l/min	X	X	X	X
Autw. Plus 1+2 GRUF 10 L	QA10DPGF	10 l/h	X	30/50 Liters	X	1,1 l/min	X	X	X	X

Stages of water purification



Osmotic Water (Type III)

Pretreatment: System of particle filters and activated carbon that remove particles ($\geq 5 \mu\text{m}$), chlorine, colloids and organic material.

Reverse Osmosis: Reverse osmosis module of high efficiency and performance, that provides with a production rate of 3/5/10 liters per hour (depending on model), removing 95-98% of dissolved inorganic salts, > 99% dissolved organic material (PM > 100 dalton) and 99.95% of microorganisms and particles.

Accumulation of Osmotic Water: The water Permeate reverse osmosis module collects it in a pressurized, sealed opaque tank that keeps it out of contact with light and air, preserving it from possible contamination.

Available pressurized 10, 30 and 50 liters tanks.

Purified Water (Type II)

Deionization: A bed of ion exchange resins of high efficiency, removes the few ions from water permeate reverse osmosis module. The result is a water conductivity of $\leq 1 \mu\text{S/cm}$

Final Filter 0,22 μm : Encapsulated filter that ensures a bacterial count $< 1 \text{ cfu/ml}$

Ultrapure Water (Type I)

Ultrapurification Module: The Type II Water produced in the deionization module, flows through a Ultrapurification module, thus reducing trace levels of ionic contaminants.

Foto-Oxidation Module: Reduces organic contamination at trace level, emitting ultraviolet radiation at 254 nm with germicidal action and 185 nm radiation capable of generating hydroxyl free radicals, which oxidize the organic compounds dissolved in water, into carbonate and bicarbonate ions. These ions will be retained by the Refining Ion module, removing traces of ions in ultrapure water and thus obtaining a resistivity of 18.2 M Ω -cm.

Polishing Module: Reduction of organic matter (TOC) removing traces of ions in Ultrapure Water, to obtain a resistivity of 18,2 M Ω .cm.

Ultrafiltration Module (Autwomatic Plus 1+2 GRUF Version): a hydrophylic membrane of encapsulated hollow fiber, with a large filtering surface, eliminates the pyrogens and nucleases in the water.

Final Filter 0,22 μm : Encapsulated filter that ensures a bacterial count $< 1 \text{ cfu/ml}$

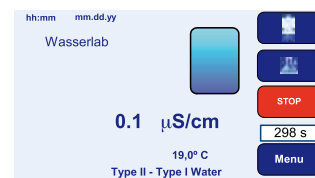

I AUTWOMATIC PLUS 1+2

Dispensation

The 1 + 2 Autwomatic Plus dispenses three water qualities independently. It allows three types of dispensing:

- | Continuous
- | Volume wise
- | Time control

Monitoring

Through a **touch screen** of 4.3", the Autwomatic Plus 1 + 2 monitors all the parameters of the water purification process of the equipment.

Water Quality

- | Measurement of the feeding water conductivity ($\mu\text{S}/\text{cm}$)
- | Measurement of the water permeate reverse osmosis module conductivity ($\mu\text{S}/\text{cm}$)
- | % perfomance of the reverse osmosis module

- | Measurement of the Type II Water conductivity ($\mu\text{S}/\text{cm}$)
- | Measurement of the produced Type I Water Resistivity ($\text{M}\Omega\cdot\text{cm}$)
- | Temperature of the water ($^{\circ}\text{C}$)

Parameter Control

- | Hours of installation and working for each item .
- | Total liters produced
- | Hours of operation of the equipment

Security

The system has a user password to allow access to different parts of the menu, as well as for parameterization of the conductivity warning.

Automatism

Automatic operation depending on the volume of stored water.

System features:

- | Stop due to water cut
- | Cleaning of the osmosis membrane
- | Programmable Type I Water Recirculation
- | Inability to dispense Type I Water with less than a preset resistivity.

The system warns about the change of consumables as well as abnormalities such as inlet water cut, or malfunction of the measuring sensors.

Maintenance, sanitization and calibration

Easy to use and maintain system.

Very quick fungible change, with cartridges with fast connection and anti-drip system.

Possibility of sanitizing the hydraulic circuit.

Equipment calibrated by certified standard traceable to national standards of the German DKD.

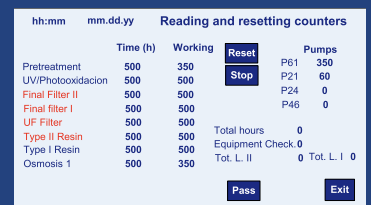
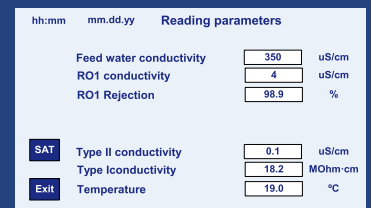
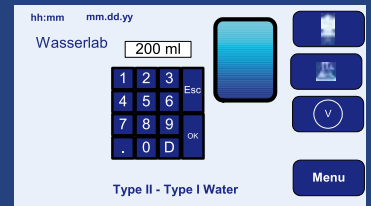
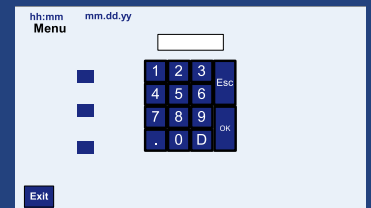



Quality of the water

Ultrapure Water (Type I)

Autwomatic 1+2 Plus GR Version

- Water Quality at 25°C
 - Resistivity 18,2 MΩ·cm.
 - TOC < 3 ppb.
 - Bacteria < 1 cfu/ml.
 - Particles < 0,22 μm.
- Dispensation 1,1 l/min.
- Applications: analytical methods such as analysis of organic and inorganic traces, HPLC, ICP-MS, IC and TOC analysis

Autwomatic Plus 1+2 GRUF Version

- Water Quality at 25°C
 - Resistivity 18,2 MΩ·cm
 - TOC < 3 ppb
 - Bacteria < 1 cfu/ml
 - Endotoxines < 0,03 (IU/ml)
 - Particles < 0,22 μm
 - RNases y DNases removal
- Dispensation 1,1 l/min
- Applications: Molecular Biology, Cell Culture, PCR, DNA sequencing, Monoclonal Antibody Production.

Purified Water (Type II)

- Water Quality at 25°C
 - Conductivity < 1 μS/cm.
 - TOC < 50 ppb.
 - Bacteria < 1 cfu/ml.
 - Particles < 0,22 μm.
- Production rate of Reverse Osmosis
 - 3 l/h
 - 5 l/h
 - 10 l/h
- Storage Tank
 - 10 Liters
 - 30 Liters
 - 50 Liters

Applications:

- Preparation of microbiological culture media.
- Preparation of reagents and buffers.
- RIA / ELISA.
- Atomic Absorption-Flame.
- Spectrophotometry.

Osmotic Water (Type III)

- Water Quality Osmotic Water. Removal of:
 - 95-98% dissolved inorganic salts.
 - > 99% of dissolved organic matter (PM > 100 dalton).
 - >99,95% microorganisms and particles.

Applications:

- Feeding of autoclaves and cleaning equipment.
- Cleaning glassware material.

Hydraulic scheme

Autwomatic plus 1+2 GR

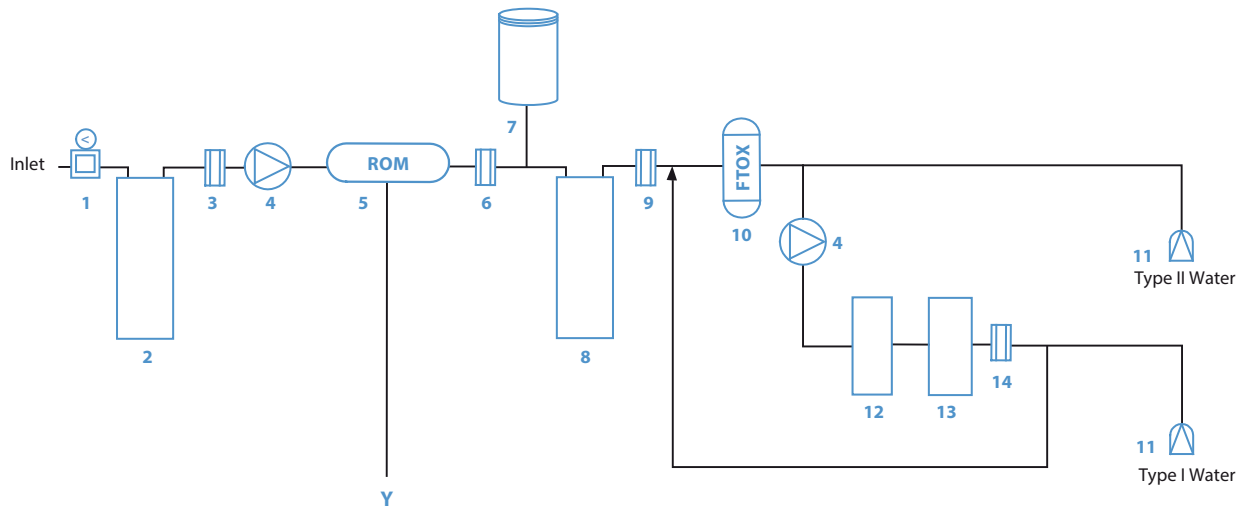

- 1** Pressure regulator. **2** Pretreatment module. **3** Inlet water conductivity sensor. **4** Pump. **5** Reverse Osmosis membrane. **6** Osmotized water conductivity sensor. **7** Pressure tank. **8** DI module. **9** Type II water conductivity sensor. **10** UV-Photo-oxidation lamp. **11** Final filter 0,22 µm. **12** Ultrapurification module. **13** Polishing module. **14** Resistivity / Temperature sensor.

Autwomatic plus 1+2 GR UF

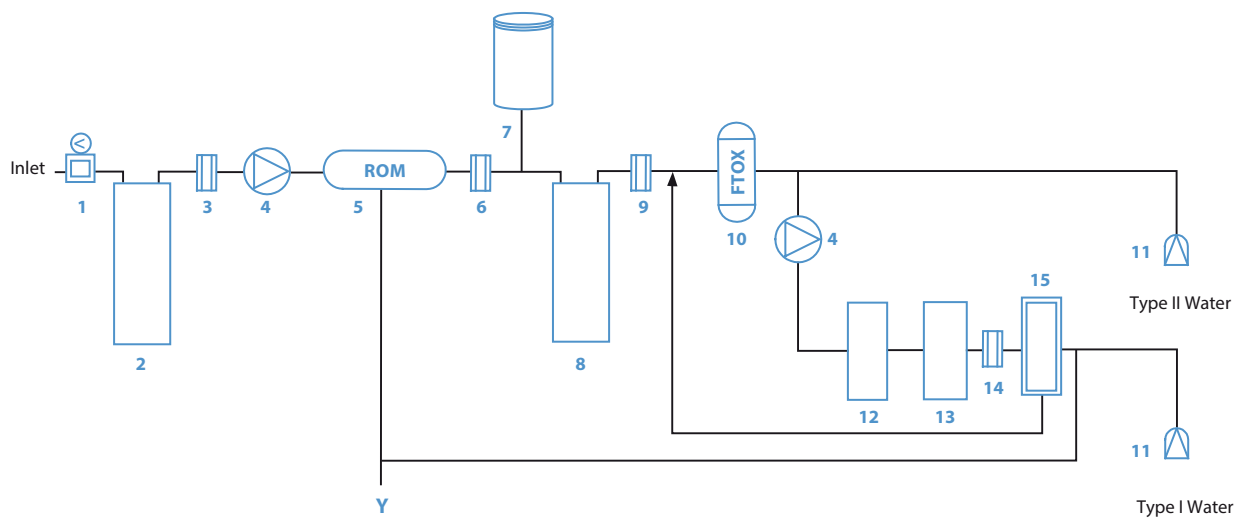

- 1** Pressure regulator. **2** Pretreatment module. **3** Inlet water conductivity sensor. **4** Pump. **5** Reverse Osmosis membrane. **6** Osmotized water conductivity sensor. **7** Pressure tank. **8** DI module. **9** Type II water conductivity sensor. **10** UV-Photo-oxidation lamp. **11** Final filter 0,22 µm. **12** Ultrapurification module. **13** Polishing module. **14** Resistivity / Temperature sensor. **15** Ultrafiltration module.

Technical specifications

Equipment		AUTWOMATIC PLUS 1+2			
Model	GR		GRUF		
	Type II	Type I	Type II	Type I	
Final Water Quality					
Water Conductivity (µS/cm)	<1	0,056	<1	0,056	
Water Resistivity (MΩ-cm)		18,2		18,2	
TOC (ppb)	< 50	< 3	< 50	< 3	
Bacteria (cfu/ml)	<1	<1	<1	<1	
Endotoxins (EU/ml)				< 0,03	
Rate and Storage					
Flow Rate	3/5/10 l/h	1,1 l/min	3/5/10 l/h	1,1 l/min	
Max. Flow rate Recommended LPD	30-50-100		30-50-100		
RO Pressurized Tank (L)	10/30/50		10/30/50		
Dispensation					
Manual Dispensing	✓	✓	✓	✓	
Volume controlled Dispensing	✓	✓	✓	✓	
Time Controlled dispensing	✓	✓	✓	✓	
Continuous Monitorization					
Touch Screen/ keyboard	Touch Screen	Touch Screen	Touch Screen	Touch Screen	
Visual and audible warning messages	✓	✓	✓	✓	
Feed Water Conductivity (µS/cm)	✓		✓		
Osmotized water Conductivity (µS/cm)	✓		✓		
Ionic Rejection %	✓		✓		
Final Water Conductivity (µS/cm)	✓		✓		
Final Water Resistivity (MΩ-cm)		✓		✓	
Work Time counter	✓	✓	✓	✓	
Multiparameter Time counter	✓	✓	✓	✓	
Water Temperature (°C)	✓	✓	✓	✓	
Temperature compensation	✓	✓	✓	✓	
Warning to user messages					
Out of range parameters	✓	✓	✓	✓	
Pretreatment cartridge exchange	✓		✓		
RO exchange	✓		✓		
DI cartridge exchange	✓	✓	✓	✓	
Ultrapure cartridge exchange		✓		✓	
UV/Photo-oxidation Lamp exchange	✓	✓	✓	✓	
Final Filter/UF exchange	✓	✓	✓	✓	
Feed water supply failure	✓		✓		
Automatizms					
Automatic Start/Stop	✓		✓		
Automatic/Programmable recirculation		Programmable		Programmable	
Automatic Stop/water supply failure	✓		✓		
Automatic RO cleaning	✓		✓		
Other components					
Photo Oxidation lamp/UV	✓	✓	✓	✓	
Final Filter 0,22 µm	✓	✓	✓	✓	
Ultrafiltration cartridge			✓	✓	
Dimensions (Height/Widht/Depth) [cm]					
	60x36x49		60x36x49		
Weight [kg]					
	35		35		
Power supply					
	110-220VAC/50-60 Hz		110-220VAC/50-60 Hz		
Feed Water Requirements					
Min. Inlet Pressure	2 bar		2 bar		
Max. Inlet Pressure	6 bar		6 bar		
Max. Water Temperature	30 °C		30 °C		
Max. Hardness	300 ppm (CaCO3)		300 ppm (CaCO3)		
SDI (Silt Density Index)	< 5		< 5		
Max. Feed Water conductivity	1500 uS/cm		1500 uS/cm		
Free Chlorine	< 1 ppm		< 1 ppm		
Turbidity	< 1NTU		< 1NTU		

ULTRAMATIC GR

ULTRAPURE WATER (Type I)

“Ultrapure Water Type I (Reagent Grade), at the lowest cost”



Ultramatic GR

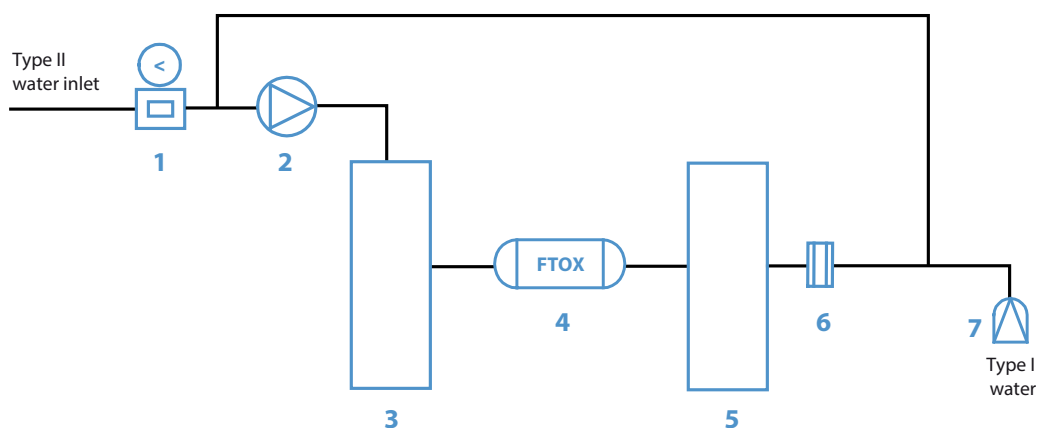

The Ultramatic GR equipment produces Type I water (Reagent Grade) according to the ASTM Quality Standards

- 1 Pressure regulator. 2 Pump. 3 GR Purification module. 4 Photo-oxidation lamp. 5 GR Purification module.
6 Resistivity / Temp. sensor. 7 Final Filter 0,22 µm.

The Wasserlab Ultramatic GR equipment produces, and instantly dispenses at user's demand, Type I Ultrapure Reagent Grade water which exceeds the ASTM quality standards, adapting to the various purity requirements of each user according to the analysis techniques applied.

Basis

Ultramatic dispenses 1.1 liters/minute of Ultrapure water Type I Reagent Grade water of 18.2 MΩ.cm at 25 °C, COT <10 ppb and bacterial count ≤1 ufc/ml, from pre purified water:

- | Type II Water(Ecomatic/Autowomatic)
- | Osmotized Water
- | Deionized Water
- | Distilled Water

The pre purified water flows through:

- | A **GR** purification module that reduces contaminating ions to traces level.
- | A photo oxidation module that reduces organic contamination to traces level.
- | The water is dispensed through a 0,22 µm amicrobic Filter.

Automatic recirculation

Ultramatic automatically recirculates the water contained in its circuit, ensuring the maximum quality of the water dispensed.

Photo-oxidation

Ultramatic includes a photo oxidation module as a base feature, and its lamp emits:

- | UV radiation at 254 nm with germicide activity (irreversibly alters bacterial DNA).
- | Radiation at 185 nm with the capacity to generate free hydroxyl radicals that oxidize the organic compounds dissolved in the water into ions, carbonate and bicarbonate which will be retained by the third **GR** purification module.

The Wasserlab Ultramatic GR equipment produces, and instantly dispenses at user's demand, Type I Ultrapure Reagent Grade water which exceeds the ASTM quality standards, adapting to the various purity requirements of each user according to the analysis techniques applied

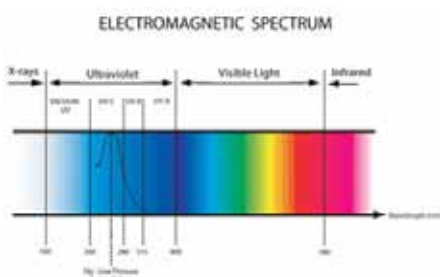

Measurement of resistivity

Ultramatic **GR** provides with a continuous measurement of the water's resistivity (± 0,1 MΩ.cm) with temperature compensation (± 0,1 °C).

As a safety mechanism for users, the equipment software includes a prefixed set point minimum value (10 MΩ.cm) the equipment does not dispense water if this value is reached.



Calibration

Equipment calibrated using certified standard traceable to international standards.

Applications

- | AA / ICP
- | HPLC / IC
- | GC-MS

ULTRAMATIC PLUS

ULTRAPURE WATER (TYPE I)

“Ultrapure water of the highest quality, for the most critical applications in your laboratory. Touch screen control”.



Ultrapure Water (Type I)

The range of **Ultramatic Plus** equipment supplies Ultrapure water of the highest quality, exceeding ASTM specifications for Type I Water, Purified Water based (Type II, distilled or RO), incorporating the highest technologies for the production and quality control of the ultrapure water obtained.

Ultramatic Plus Model configurations

Versions	Code	Ultrapure Water Type I						
		Flow rate	Ultrapurification Module	Ionic Polishing Module	Photo-oxidation Lamp	Polishing Module	Ultrafiltration Module	Final Filter 0,22 µm
Ultramatic Plus DI	QUDI0011	1,1 l/min.	X	X	-	-	-	X
Ultramatic Plus GR	QUGR0011	1,1 l/min.	X	-	X	X	-	X
Ultramatic Plus GR UF	QUGF0011	1,1 l/min.	X	-	X	X	X	X

Water Quality

Model	Ultramatic Plus DI	Ultramatic Plus GR	Ultramatic Plus GR UF
Dispensing	1,1 l/min.	1,1 l/min.	1,1 l/min.
Resistivity	18,2 MΩ·cm.	18,2 MΩ·cm.	18,2 MΩ·cm.
TOC	< 10 ppb	< 3 ppb	< 3 ppb
Bacterial count	< 1 cfu/ml	< 1 cfu/ml	< 1 cfu/ml
Endotoxins	-	-	0,03 IU/ml
Particles	0,22 µm	0,22 µm	Ultrafiltration
RNase y DNase	-	-	Removal



I ULTRAMATIC PLUS



Stages of the Ultrapurification of the water

Water Quality

Ultramatic Plus DI

Applications:

- Analysis of Inorganic traces.
- AA, IC, ICP-MS.
- Photometry.

Ultramatic Plus GR

Applications:

- Analytical methods such as analysis of organic and inorganic trace, HPLC, ICP-MS, IC and TOC analysis.

Ultramatic Plus GR UF

Applications:

- Molecular Biology, Cell Culture, PCR, DNA sequencing, production of monoclonal antibodies.

Ultrapurification Module (Ultramatic Plus GR and GR UF versions)

Purified feed water flows through a Ultrapurification module reducing trace levels of ionic contaminants, in order to reach a resistivity of 18,2 MΩ.cm.

Ionic Polishing Module (Ultramatic Plus DI version)

Final deionization by ion exchange resin beds, removing ionic contaminants at trace levels, obtaining Ultrapure Water (Type I) of a resistivity of 18,2 MΩ.cm.

Photo -Oxidation Module (Ultramatic Plus GR and GR UF versions)

Reduces organic contamination at trace level, emitting ultraviolet radiation at 254 nm with germicidal action and 185 nm radiation capable of generating hydroxyl free radicals, which oxidize the organic compounds dissolved in water, into carbonate and bicarbonate ions. These ions will be retained by the Refining Ion module, removing traces of ions in ultrapure water and thus obtaining a resistivity of 18,2 MΩ.cm.

Polishing module (Ultramatic Plus GR and GR UF version)

Reduction of organic matter (TOC) removing traces of ions in ultrapure water, to obtain a resistivity of 18,2 MΩ.cm.

Ultrafiltration Module (Ultramatic Plus GR UF version)

For the more critical applications in Molecular Biology (PCR, DNA sequencing, cellular cultures, electrophoresis....) a hydrophilic membrane of encapsulated hollow fiber, with a large-filtering surface, eliminates the pyrogens and nucleases in the water.

Final Filter 0,22 µm

Final amicrobic encapsulated filter 0,22 µm, with high-flow membrane and no removables for particle retention and bacterial count ≤1 cfu/ml.

Dispensation

The Ultramatic Plus dispenses three water qualities independently:

- Continuous
- Volume wise
- Time control

Monitoring

Through a touch screen of 4.3", the Ultramatic Plus monitors all the parameters of the water purification process of the equipment.

Water Quality

- Measurement of the feeding water conductivity ($\mu\text{S}/\text{cm}$)
- Measurement of the produced Type I Water Resistivity ($\text{M}\Omega\cdot\text{cm}$)
- Temperature of the water ($^{\circ}\text{C}$)

Parameter Control

- Hours of installation and working times for each item of the equipment.
- Total liters produced.
- Hours of operation of the equipment.

Security

The system has a user password to allow access to different areas of the menu, and to access certain features such as:

- Access to the configuration menus and reset counters.
- Definition of dispensing type.

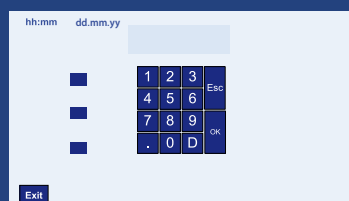
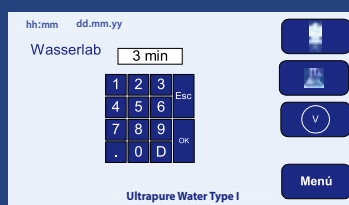
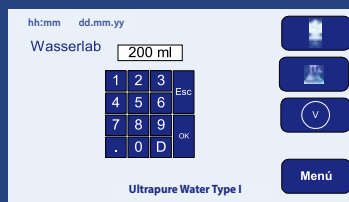

Automatism

Programmable Type I Water Recirculation:

- Programmed auto recirculation system: Automatically recirculates the water in the circuit, ensuring the highest quality of water dispensed.
- Inability to dispense Type I Water if resistivity is below preset level.

The system warns about the change of consumables as well as abnormalities such as inlet water cut, or malfunction of the measuring sensors.

Maintenance, sanitization and calibration

Easy to use and maintain system.

Very quick Fungible change, with cartridges with fast connection and anti-drip system.

Possibility of sanitizing the hydraulic circuit.

Equipment calibrated by certified standard traceable to national standards of the German DKD.

CE Certificated.

Ultramatic Plus DI

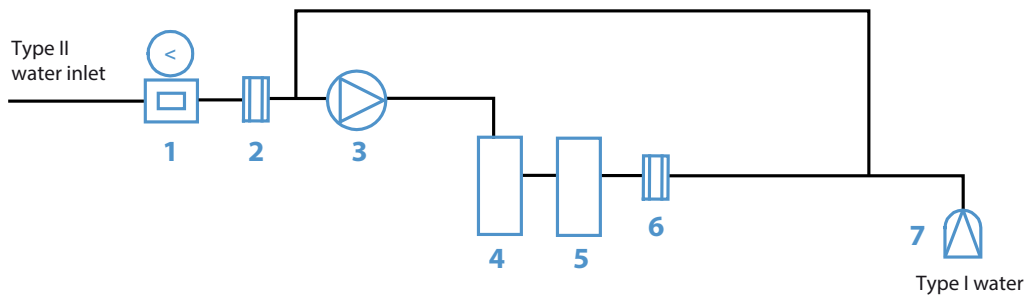

- 1** Pressure regulator. **2** Type II Water Conductivity / Temp sensor. **3** Pump. **4** Ultrapurification module.
5 Ionic Polishing module. **6** Resistivity / Temp. sensor **7** Final Filter 0.22 µm.

Ultramatic Plus GR

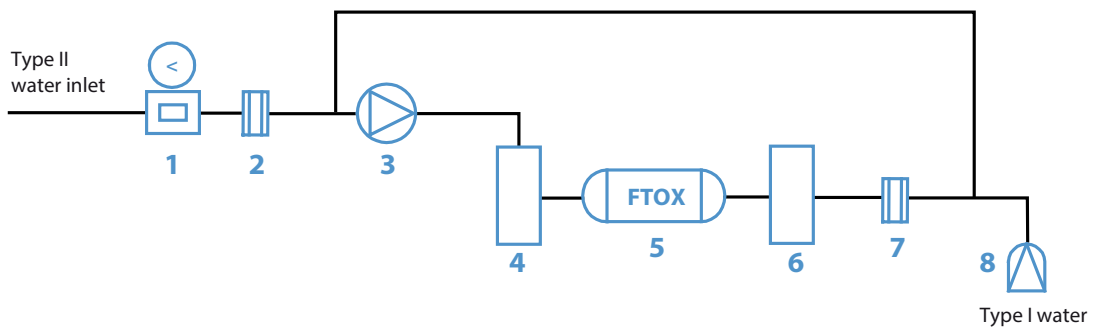

- 1** Pressure regulator. **2** Type II Water Conductivity / Temp sensor. **3** Pump. **4** Ultrapurification module.
5 Photo-Oxidation lamp. **6** Polishing Module. **7** Resistivity / Temp. sensor. **8** Final Filter 0,22 µm.

Ultramatic Plus GR UF

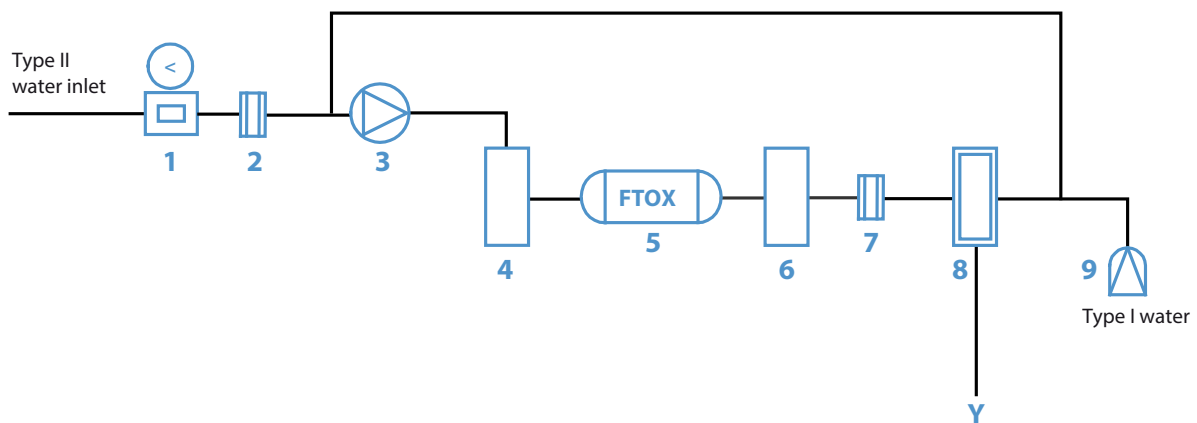

- 1** Pressure regulator. **2** Type II Water Conductivity / Temp sensor. **3** Pump. **4** Ultrapurification module.
5 Photo-Oxidation lamp. **6** Polishing Module. **7** Resistivity / Temp. sensor. **8** Ultrafiltration Module.
9 Final Filter 0,22 µm.

Ultramatic GR - Ultramatic Plus Technical specifications

Equipment	ULTRAMATIC GR		ULTRAMATIC PLUS	
Model	GR	DI	GR	GR UF
Final Water Quality	Type I	Type I	Type I	Type I
Water Conductivity (µS/cm)	0,056	0,056	0,056	0,056
Water Resistivity (MΩ-cm)	18,2	18,2	18,2	18,2
TOC (ppb)	<10	<10	<3	<3
Bacteria (cfu/ml)	<1	<1	<1	<1
Endotoxins (EU/ml)				<0,03
Rate and Storage				
Flow Rate LPH	1,1 l/min	1,1 l/min	1,1 l/min	1,1 l/min
Dispensation				
Manual Dispensing	✓	✓	✓	✓
Volume controlled Dispensing		✓	✓	✓
Time Controlled dispensing		✓	✓	✓
Continuous Monitorization				
Touch Screen/ keyboard	Keyboard	Touch Screen	Touch Screen	Touch Screen
Visual and audible warning messages	✓	✓	✓	✓
Feed Water Conductivity (µS/cm)		✓	✓	✓
Final Water Resistivity (MΩ-cm)	✓	✓	✓	✓
Work Time counter		✓	✓	✓
Multiparameter Time counter		✓	✓	✓
Water Temperature (°C)	✓	✓	✓	✓
Temperature compensation	✓	✓	✓	✓
Warning to user messages				
Out of range parameters	✓	✓	✓	✓
Ultrapurification module exchange		✓	✓	✓
GR Purification module exchange	✓			
Photo-oxidation lamp exchange			✓	✓
Final Filter exchange		✓	✓	✓
Ultrafiltration module exchange				✓
Automatism				
Automatic/Programmable recirculation	Automatic	Programmable	Programmable	Programmable
Other components				
Photo-oxidation Lamp	✓		✓	✓
Final Filter 0,22 µm	✓	✓	✓	✓
Ultrafiltration module				✓
Dimensions (Height/Widht/Depth) [cm]	52x25x48	60x36x49	60x36x49	60x36x49
Weight [kg]	12	35	35	35
Power supply	110-220 VAC / 50-60 Hz	110-220 VAC / 50-60 Hz	110-220 VAC / 50-60 Hz	110-220 VAC / 50-60 Hz
Feed Water Requirements				
Min. Inlet Pressure	1 bar	1 bar	1 bar	1 bar
Max. Inlet Pressure	6 bar	6 bar	6 bar	6 bar
Max. Water Temperature	30 °C	30 °C	30 °C	30 °C
Max. Feed Water conductivity	20 µS/cm	20 µS/cm	20 µS/cm	20 µS/cm



A large number of customers already trust the Wasserlab products

- Universities from all over the world
- Leading research centers
- Hospitals
- Laboratory equipment manufacturers market leaders

The advantages of our Systems

Stable quality
Reliability
Easy and efficient handling

DISTRIBUTED BY:

www.wasserlab.com

Pol. Ind. Comarca II • Calle A, nº 26
31191 Barbatain (Navarra) Spain • T +34 948 186 141